

AS Level Physics A

H156/01 Breadth in Physics

Question Set 3 – Module 4 MCQ

1 Which statement is **not** correct about an electromagnetic wave?

- A It can be diffracted.
- B It can be polarised.
- C It is a longitudinal wave.
- D It can travel through a vacuum.

Your answer

[1]

2 A narrow beam of light in air is directed at the surface of a triangular glass prism.

Which is the correct diagram for the light refracted by the prism?

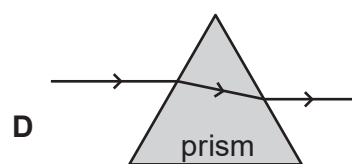
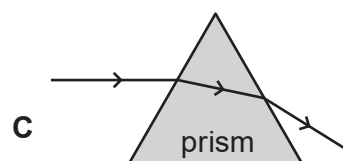
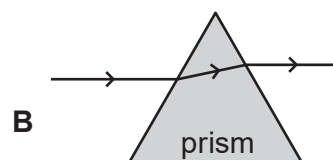
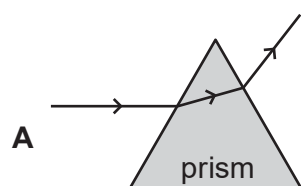

Your answer

[1]

3 A potential divider circuit with a light-dependent resistor (LDR) is shown below.

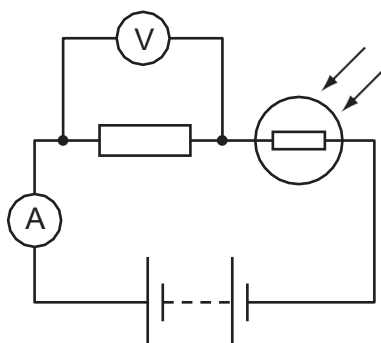

The intensity of the light incident on the LDR is reduced.

Which row correctly describes the observed change on the ammeter and voltmeter readings?

	Ammeter reading	Voltmeter reading
A	decreases	decreases
B	decreases	increases
C	increases	stays the same
D	stays the same	decreases

Your answer

[1]

4 The minimum potential difference across a light-emitting diode (LED) before it conducts is 2.1 V. The wavelength of the light emitted by the LED is λ .

e = elementary charge

c = speed of light in a vacuum

What is the correct expression for determining the Planck constant h ?

A $h = 2.1ec\lambda$

B $h = \frac{2.1e}{\lambda}$

C $h = \frac{c}{2.1e\lambda}$

D $h = \frac{2.1e\lambda}{c}$

Your answer

[1]

- 5 Two filament lamps **X** and **Y** are connected in parallel to a supply. The power dissipated by lamp **X** is 24 W and the power dissipated by lamp **Y** is 6.0 W. The supply has electromotive force (e.m.f.) 12 V and negligible internal resistance.

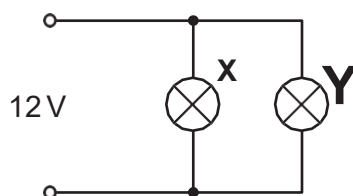

What is the total current drawn from the supply by the lamps?

- A 0.4A
- B 0.5A
- C 2.0A
- D 2.5A

Your answer

- 6 The de Broglie wavelength of an electron after being accelerated through a potential difference (p.d.) V is λ_0 . The accelerating p.d. is now doubled.

What is the new de Broglie wavelength of the electron in terms of λ_0 ?

- A $\frac{\lambda_0}{2}$
- B $\frac{\lambda_0}{\sqrt{2}}$
- C $\sqrt{2}\lambda_0$
- D $2\lambda_0$

Your answer

[1]

- 7 The intensity of a laser beam is 2.0 W m^{-2} . The cross-sectional area of the beam is 1.0 mm^2 .

What is the energy delivered by the laser beam in a time of 100 s?

- A $2.0 \times 10^{-6} \text{ J}$
- B $2.0 \times 10^{-4} \text{ J}$
- C $2.0 \times 10^{-1} \text{ J}$
- D $2.0 \times 10^1 \text{ J}$

Your answer

[1]

- 8 The diagram below shows a circuit connected by a student.

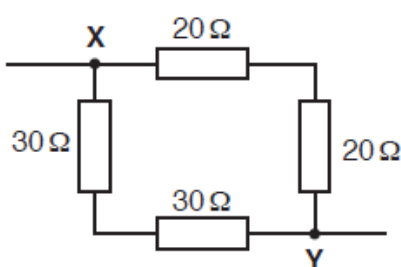

What is the total resistance of the circuit between points **X** and **Y**?

- A 24Ω
- B 29Ω
- C 38Ω
- D 100Ω

Your answer

[1]

- 9 Wire **P** has length L , diameter d and a resistance of 1.00Ω . Another wire **Q** made from the same metal has length $3L$ and diameter $2d$.

What is the resistance of wire **Q**?

- A 0.750Ω
- B 1.00Ω
- C 1.33Ω
- D 1.50Ω

Your answer

[1]

- 10 Two filament lamps **X** and **Y** are connected in series with a 16 V d.c. supply. The supply has negligible internal resistance.

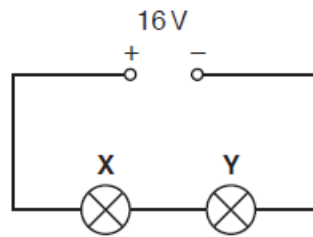

Lamp **X** emits a power of 2.0 W and lamp **Y** emits a power of 6.0 W.

What is the potential difference across the lamp **X**?

- A 1.0 V
- B 4.0 V
- C 12 V
- D 16 V

Your answer

[1]

- 11 Two resistors of resistances $2.0\ \Omega$ and $4.0\ \Omega$ are connected in series across the terminals of a cell of e.m.f. 1.4 V and internal resistance $1.0\ \Omega$.

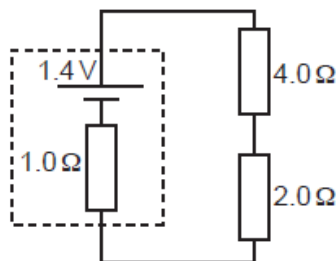

What is the potential difference across the $2.0\ \Omega$ resistor?

- A 0.40 V
- B 0.47 V
- C 0.80 V
- D 0.93 V

Your answer

[1]

- 12 The intensity of light incident on a light-dependent resistor (LDR) is increased. Its resistance decreases.
Which statement gives the correct reason for this behaviour?
- A The cross-sectional area of the LDR decreases.
 - B The mean drift velocity of the charge carriers decreases.
 - C The number density of the charge carriers increases.
 - D The magnitude of the charge on the charge carriers increases.

Your answer

[1]

- 13 The total energy gained by 20 electrons travelling through a potential difference V is 30 keV.
What is the potential difference V ?
- A 1.5 V
 - B 3.0 V
 - C 1500 V
 - D 3000 V

Your answer

[1]

- 14 The current at a point in a circuit is 10 mA.
Expressed to the nearest power of ten, how many electrons pass the point in 10 s?
- A 10^2
 - B 10^{15}
 - C 10^{18}
 - D 10^{21}

Your answer

[1]

- 15 Electromagnetic radiation is incident on a metal. The radiation has constant wavelength with each photon having an energy of 5.0 eV. The work function of the metal is 3.0 eV.

Which of the following **cannot** be the kinetic energy of an emitted photoelectron?

- A 0 eV
- B 1.0 eV
- C 2.0 eV
- D 3.0 eV

Your answer

[1]

- 16 The waves emitted from two sources are coherent. Which quantity must be constant for these emitted waves?

- A amplitude
- B frequency
- C intensity
- D phase difference

Your answer

[1]

- 17 The diagram below shows a stationary wave pattern for a sound wave in a tube. The tube has one open end and one closed end.

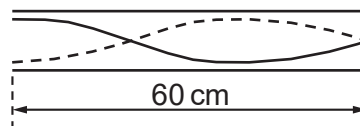

The length of the tube is 60 cm.
What is the wavelength of the sound?

- A 20 cm
- B 40 cm
- C 60 cm
- D 80 cm

Your answer

[1]

18 Which circuit below can be used to monitor the variation of light intensity in a room?

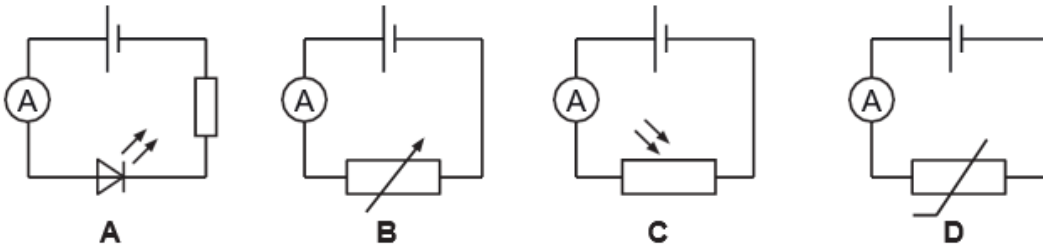

Your answer

[1]

19 A household is planning to change all their 60 W filament bulbs to 12 W LED bulbs. The household has a total of 10 bulbs. Each bulb will be used for about 2000 hours in one year. The cost of 1 kWh is 15.4 p.

What would the annual saving be?

- A £7.39
- B £36.96
- C £147.84
- D £184.80

Your answer

[1]

20 The resistance of a wire of length L is $3.00\ \Omega$. The wire is extended so that its length becomes $1.50L$. Its volume remains the same.

What is the resistance of the extended wire?

- A $2.00\ \Omega$
- B $3.00\ \Omega$
- C $4.50\ \Omega$
- D $6.75\ \Omega$

Your answer

[1]

21 The diagram below shows a potential divider circuit.

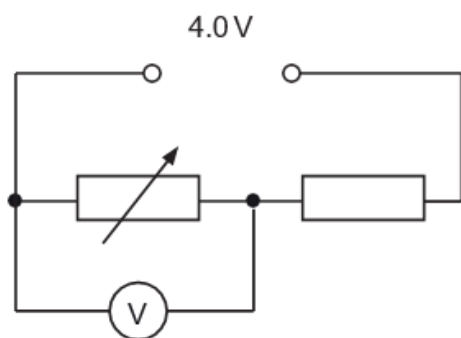

The minimum resistance of the variable resistor is zero and its maximum resistance is $3R$, where R is the resistance of the fixed resistor.

The power supply has electromotive force (e.m.f.) 4.0 V and negligible internal resistance. The voltmeter has infinite resistance.

The resistance of the variable resistor is changed from its minimum to its maximum value.

How does the voltmeter reading change?

- A from 0 V to 1.0 V
- B from 0 V to 3.0 V
- C from 1.0 V to 4.0 V
- D from 3.0 V to 4.0 V

Your answer

[1]

- 22 The waves from the sources **X** and **Y** are coherent and have wavelength 10.0 cm. The waves are in phase at **X** and **Y**.

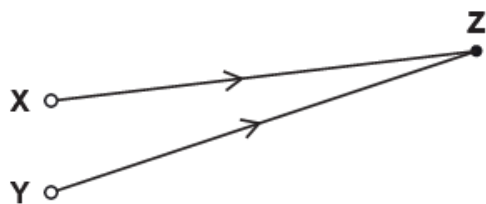

Which row gives the correct conditions for constructive interference at point **Z**?

	Distance XZ/ cm	Distance YZ/ cm
A	60.0	75.0
B	75.0	95.0
C	90.0	65.0
D	100.0	135.0

Your answer

[1]

- 23 The table shows the refractive index n of four transparent materials **A**, **B**, **C** and **D**.

Which material has the **smallest** critical angle?

Material	A	B	C	D
n	2.01	1.87	1.60	1.33

Your answer

[1]

- 24 In a particle-accelerator electrons are accelerated through a potential difference of 120 kV. The electron beam current is 8.0 μA .

What is the total energy transferred to the electrons in a time of 2.0 hours?

- A** 0.96 J
- B** 120 J
- C** 1900 J
- D** 6900 J

Your answer

[1]

25 The electric charge on particles is quantised and a multiple of the elementary charge.

Which charge on a particle is possible?

- A $1.0 \times 10^{-19} \text{ C}$
- B $4.0 \times 10^{-19} \text{ C}$
- C $8.0 \times 10^{-19} \text{ C}$
- D $8.8 \times 10^{-19} \text{ C}$

Your answer

[1]

26 Which of the following waves can be polarised and has a typical wavelength of about a few centimetres?

- A microwaves
- B ultraviolet
- C sound
- D visible light

Your answer

[1]

27 Stationary sound waves are produced in the air inside a tube. The tube is closed at one end.

Which pattern of nodes (N) and antinodes (A) is likely to be correct?

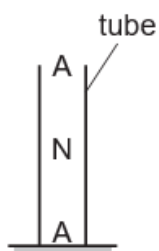

A

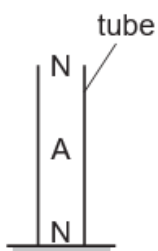

B

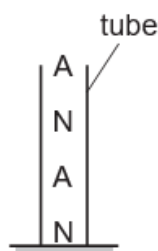

C

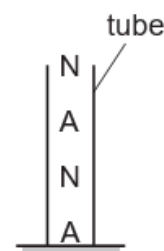

D

Your answer

[1]

Total Marks for Question Set 3: 27

OCR

Oxford Cambridge and RSA

Copyright Information

OCR is committed to seeking permission to reproduce all third-party content that it uses in its assessment materials. OCR has attempted to identify and contact all copyright holders whose work is used in this paper. To avoid the issue of disclosure of answer-related information to candidates, all copyright acknowledgements are reproduced in the OCR Copyright Acknowledgements Booklet. This is produced for each series of examinations and is freely available to download from our public website (www.ocr.org.uk) after the live examination series.

If OCR has unwittingly failed to correctly acknowledge or clear any third-party content in this assessment material, OCR will be happy to correct its mistake at the earliest possible opportunity.

For queries or further information please contact The OCR Copyright Team, The Triangle Building, Shaftesbury Road, Cambridge CB2 8EA.

OCR is part of the Cambridge Assessment Group; Cambridge Assessment is the brand name of University of Cambridge Local Examinations Syndicate (UCLES), which is itself a department of the University of Cambridge